



GSC

VAR: GSC

www.gsc-3d.com

GLSV, INC.

*SPEEDING UP NOISE/VIBRATION TEST SYSTEM DEVELOPMENT
WITH SOLIDWORKS ELECTRICAL 3D*

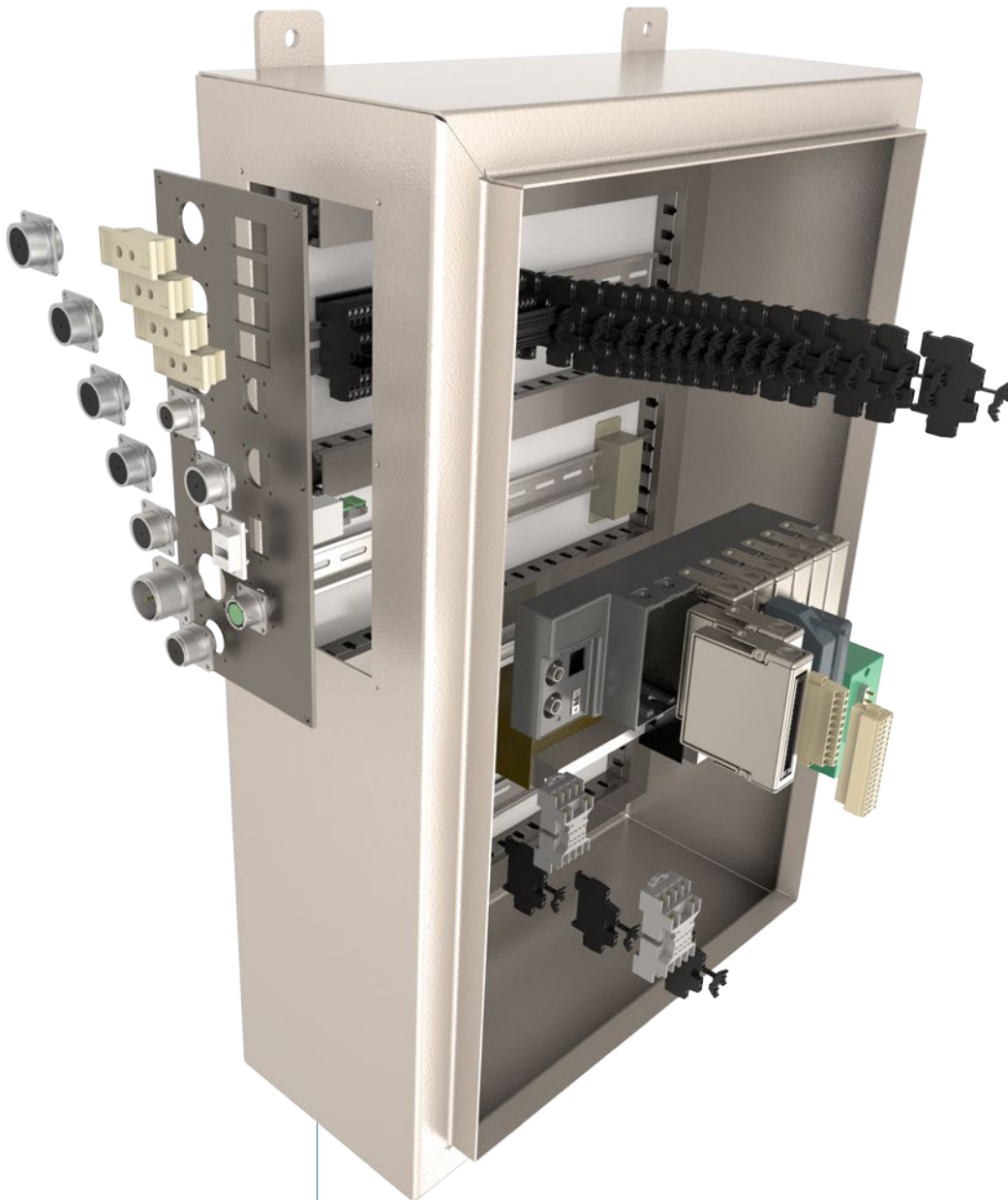

By implementing SOLIDWORKS Electrical 3D software, GLSV has cut electrical design time for its noise/vibration test systems in half while also realizing greater efficiencies in mechanical design.



Challenge:

Integrate the electrical and mechanical design of noise/vibration test systems to save time and optimize footprint sizes.

Solution:

Implement SOLIDWORKS Electrical 3D design software in concert with SOLIDWORKS Professional and SOLIDWORKS Premium mechanical design software.

Results:

- Cut electrical design time by 50 percent
- Improved quality of schematics
- Reduced electrical cabinet sizes by 25 percent
- Reduced errors through automated BOM creation

GLSV, Inc. has leveraged its extensive noise and vibration engineering experience in the defense, marine, automotive, off-highway, and recreation vehicle markets to become the go-to firm for solving acoustics, vibration, and shock-related problems. GLSV's expertise has allowed the firm to expand its capabilities not only to include structural design and analysis, custom prototyping, and low-volume manufacturing, but also to encompass complete exhaust system development and noise/vibration test system design and fabrication.

Since 2004, GLSV has relied on SOLIDWORKS® Professional and SOLIDWORKS Premium software for the mechanical design of its noise/vibration test systems, with electrical schematics created in Microsoft® Visio® 2D software. According to Project Engineer Ryan Helminen, who handles electrical design of GLSV systems, working in Visio software had become tedious and time-consuming, especially in connection with generating bill of materials (BOM) information.

"While Visio allowed me to create a basic 2D electrical schematic, that's all I could do," Helminen explains. "There wasn't any cross-referencing to components or subassemblies—requiring manual input of BOM information—and no integration with the overall mechanical design. Because all references had to be input manually, it took a lot of time and created the opportunity for errors to creep in when production and assembly tried to read the schematic and match it to the BOM."

To improve the efficiency and quality of test system development and fabrication, GLSV evaluated available electrical design solutions in 2012. The company chose SOLIDWORKS Electrical 3D software because it's easy to use, automatically generates BOM data, improves the quality of 3D electrical schematics, and integrates directly with SOLIDWORKS mechanical design solutions.

"SOLIDWORKS Electrical is to electrical design what SOLIDWORKS is to mechanical design," Helminen notes. "Because we already used SOLIDWORKS software, we expected the integration provided by SOLIDWORKS Electrical to both save time and improve quality, which it has."

FASTER ELECTRICAL DESIGN, OPTIMIZED FOOTPRINTS

Since implementing SOLIDWORKS Electrical 3D software, GLSV has cut its electrical design times in half. The software also helps the company optimize sizing requirements for test systems so that they take up less space. "SOLIDWORKS Electrical makes us more accurate and efficient in all facets of development—from design to collaboration to production," Helminen stresses. "In addition to increasing productivity, SOLIDWORKS Electrical helps improve our final products."

For example, on a vibration test stand that was custom-designed for a small-engine manufacturer, GLSV was able to optimize the sizing requirements for electrical systems by working more accurately in 3D. "Before we implemented SOLIDWORKS Electrical, we'd get a general idea of the space needs in 2D, and then make it 25 percent bigger," Helminen explains. "With the greater accuracy of SOLIDWORKS Electrical, we no longer have to oversize designs and can cut sizing closer to what's actually necessary. With this capability, we can satisfy customer demand for smaller footprints."



"For systems developed in SOLIDWORKS Electrical software, we're seeing higher quality in production and assembly because it's easier for manufacturing personnel to read an information-rich schematic that's tightly linked to actual BOM information."

— Ryan Helminen, Project Engineer

BETTER SCHEMATICS AND AUTOMATED BOMS BOOST QUALITY

Using SOLIDWORKS Electrical software, GLSV has realized quality improvements in concert with greater efficiencies. The combination of higher quality 3D electrical schematics and automatically generated, completely accurate BOM information has resulted in fewer errors when designs are released to Manufacturing.

“For systems developed in SOLIDWORKS Electrical software, we’re seeing higher quality in production and assembly because it’s easier for manufacturing personnel to read an information-rich schematic that’s tightly linked to actual BOM information,” Helminen points out. “No one is manually looking up part numbers anymore. All of the information that Production and Assembly needs to manufacture the design is part of the higher quality schematics and complete BOM information that we can now generate with SOLIDWORKS Electrical.”

MAKING ELECTRICAL AND MECHANICAL DESIGN MORE EFFICIENT

GLSV has realized additional efficiencies in mechanical design through the greater collaboration afforded by integrated SOLIDWORKS Electrical 3D software. Instead of recreating electrical system components in SOLIDWORKS—as GLSV mechanical engineers did in the past—SOLIDWORKS Electrical automatically populates the mechanical design, providing additional time savings.

“Working on a single platform saves time because unnecessary, duplicated steps are eliminated,” Helminen says. “It also improves collaboration because we’re both using the same tool to gain a more accurate understanding of how the electrical systems support the operation of the mechanical design and the space that we both have to work with. Our mechanical engineers love SOLIDWORKS Electrical for the same reasons that I do—because it saves them time and busy work. Integrating electrical and mechanical design provides a lot more continuity throughout the entire process.”

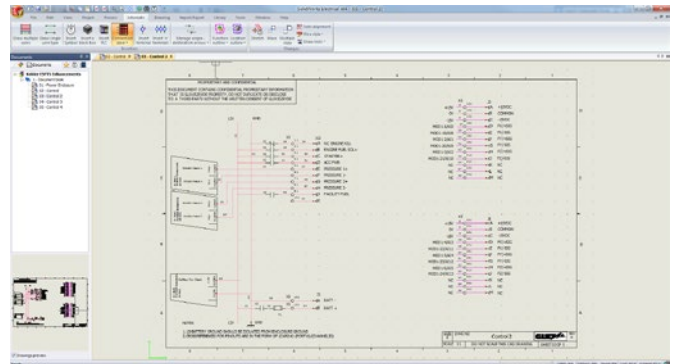
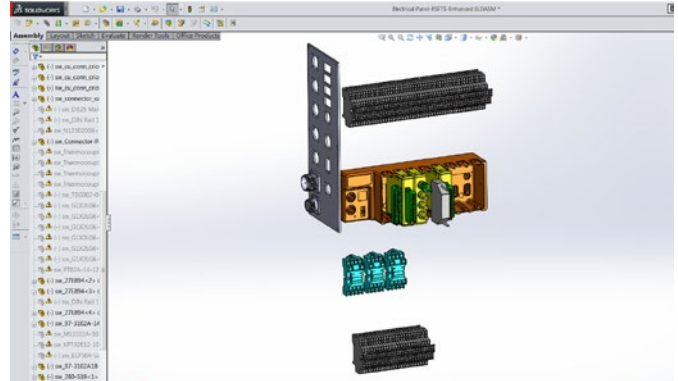

GLSV, Inc.
Headquarters: MI
906 482 7535

VAR: GSC
800 454 2233

For more information:
www.gsc-3d.com

With the improved accuracy afforded by SOLIDWORKS Electrical 3D, GLSV has reduced electrical cabinet sizes to what’s actually necessary, helping the company satisfy customer demand for smaller footprints.



WWW.GSC-3D.COM
800-454-2233